

Código: C066

Compatível com os Cabos

DLC 58
LMR 195
RG 58

Características Mecânicas

Interface	TNC macho
Formato	Reto
Acoplamento	Porca Sextavada 9/16"
Fixação do Condutor Interno	Solda
Fixação no Cabo	Clamp. Chaves: 5/8" e 7/16"
Temperatura de Trabalho	-65 a 165 °C

Características Elétricas

Impedância Nominal	50 ohms
Frequência de Trabalho	0 a 3,0 GHz
VSWR (máx)	1.15

Materiais e Acabamento

Parte do conector	Material	Acabamento
Condutor interno	Latão CuZn36Pb3 (DIN 17660)	Prata
Demais peças metálicas	Latão CuZn36Pb3 (DIN 17660)	Níquel
Isolantes	PTFE (ASTM D-1457)	
Vedações	Neoprene	

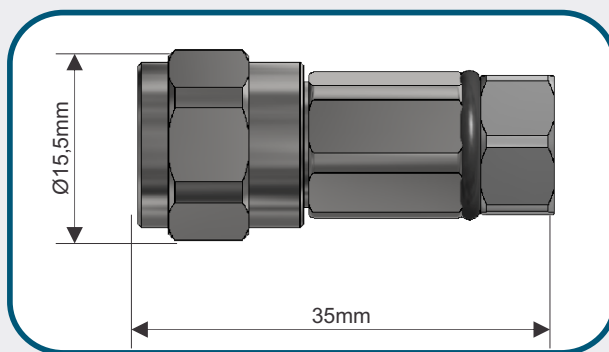

Código: C066

Compatible con los cables

DLC 58
LMR 195
RG 58

Características Mecánicas

Interfaz	TNC macho
Formato	Recto
Acople	Tuerca Hexagonal 9/16"
Fijación del Conductor Interno	Soldadura
Fijación en el Cable	Clamp. Llaves: 5/8" e 7/16"
Temperatura de Trabajo	-65 a 165 °C

Características Eléctricas

Impedancia Nominal	50 ohms
Frecuencia de Trabajo	0 a 3,0 GHz
VSWR (máx)	1.15

Materiales y Acabado:

Parte del conector	Material	Acabado
Conductor interno	Latón CuZn36Pb3 (DIN 17660)	Plata
Demás piezas metálicas	Latón CuZn36Pb3 (DIN 17660)	Níquel
Aislantes	PTFE (ASTM D-1457)	
Sellados	Neopreno	

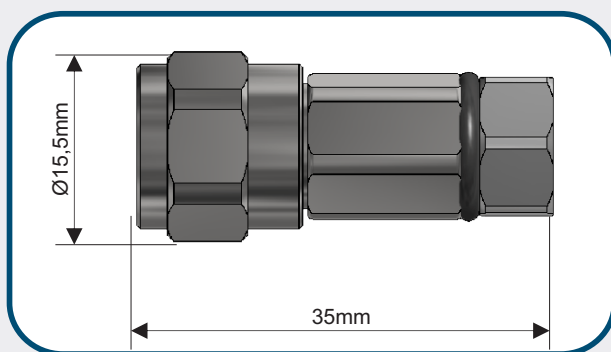

Part number: C066

Cable

DLC 58
LMR 195
RG 58

Mechanical Characteristics

Interface	TNC male
Format	Straight
Coupling	9/16" Hex nut
Inner Contact Attach	Solder
Outer Contact Attach	Clamp
Temperature Rating	-65 to 165 °C

Electrical Characteristics

Nominal Impedance	50 ohms
Frequency Range	0 to 3,0 GHz
VSWR (máx)	1.15

Materials and Finishing

Connector part	Material	Finish
Spring effect parts	Brass CuZn36Pb3 (DIN 17660)	Silver
Other metallic parts	Brass CuZn36Pb3 (DIN 17660)	Nickel
Insulators	PTFE (ASTM D-1457)	
Gaskets	Neoprene	

DataLink reserves the right to change the information mentioned herein without prior notice.

